



China

HollySys Group (Group Headquarters)
No.2 Di Sheng Middle Road, Economic-Technological Development Area, Beijing 100176
Tel: +86 10 58981000 Fax: +86 10 58981100
Hangzhou HollySys Automation Co., Ltd. (Industrial Automation Headquarters)
No.1 North No.19 Street, Qiantang District, Hangzhou 310018
Tel: +86 571 81633600 Fax: +86 571 81633700

Singapore

HollySys (Asia Pacific) Pte. Ltd. (International Headquarters)
Changi Business Park Crescent, #04-01/02/03 Plaza 8 @ CBP, Tower A, Singapore 486025
Tel: +65 6777 0950 Fax: +65 6777 2730

India

HollySys Automation India Pvt. Ltd.
D-84, Ground Floor, Sector 63, Noida, Uttar Pradesh 201301
Tel: +91 12045 50652

Indonesia

PT. HollySys Automation Indonesia
Metropolitan Tower, 10th Floor Unit E, Jl. R.A. Kartini Kav. 14, Jakarta 12430
Tel: +62 21 2918 2926 Fax: +62 21 2918 2936

Web: www.hollysys.com
E-mail: sales_international@hollysys.com (Sales)
iaservice@hollysys.com (After-sales Service)

HOLLiAS MACS-K DISTRIBUTED CONTROL SYSTEM

Intelligence
For Excellence

Profile

Founded in 1993, HollySys is a leading supplier of intelligence solutions with more than 4,700 employees and operates in both China and abroad. HollySys is headquartered in Beijing with R&D, production, and service bases in Beijing, Hangzhou, Xi'an, Singapore, and local branches in major cities in China, as well as offices in India, Malaysia and Indonesia, establishing a comprehensive service network across the world.

HollySys business consists of industrial intelligence, transportation intelligence, and food and pharmaceutical intelligence, covering the main industries for the national economy and the people's livelihood. With years of technological accumulation in various fields and continuous capacity building, we can provide customers with customized integrated solutions, stable and reliable products, and full lifecycle services, helping them improve market competitiveness. Over the past three decades, we have served more than 35,000 clients, successfully completed more than 45,000 projects, and gained more than 1,000 new clients each year, making HollySys a world-renowned brand in automation and intelligence field.

The HOLLiAS industrial control platform of HollySys features a series of advanced, practical and reliable industrial automation systems and HollySys automation instrumentations products. The system products include MACS-K, MACS-S industrial control system DCS, professional control systems such as DEH, ETS and SIS, and whole-process information-based software for manufacturing enterprises. Instrumentation products include isolated safety barriers, signal isolators, surge protectors, power transmitters, pressure transmitters, electromagnetic flowmeters, metal tube float meters, magnetic level gauges, radar level gauges, throttling elements, thermal elements, and pressure gauges.

The company's products have been successfully applied to major projects and key equipment, including 1000MW ultra-supercritical thermal power units, 1.2 million tons of urea and 5 million tons of oil refining main units, earning a good reputation in the industry.

Specializing in HollySys Instrumentation and control system engineering and integration, the company can provide both new and brown field projects of enterprises with HollySys proprietary products, as well as comprehensive engineering services such as customized design and construction & commissioning.

HollySys has always pursued continuous innovation and R&D while sticking to its vision "create the most valuable intelligent company through stable and sustainable development" to provide more reliable, secure, and intelligent technology and products for our customers.

Contents

System Overview	1
System Network Architecture	3
· Enterprise Management Level	3
· Process Optimization Level	3
· Process Control Level	4
System Hardware	7
· Cabinet	7
· Power Supply	8
· Controller	11
· IO-BUS Modules	13
· I/O Module	18
· Communication Modules	19
· Other Modules	22
System Software	24
· Overview	24
· Configuration and Management Software	28
· System Online Monitoring Software	28
· Controller Operation System Software	28
· Other Auxiliary Software	28
· Advanced Application Software	29
Appendix1 System Parameters	30
Appendix2 System Capability	30
Appendix 3 Module List	31

System Overview

HOLLiAS MACS-K is HollySys'proprietary integrated industrial automation system based on advanced automation technology. With an open system software platform, and integration of HollySys' mature experience in development and use of automation systems, this system can provide professional solutions and platform to meet various automation control needs in different industries.

The hardware of HOLLiAS MACS-K system fully absorbs the latest achievements of international industrial electronic technologies and industrial control technologies, strictly follows international advanced industrial standards, adopts reliability design technologies such as full redundancy, multiple isolation and diagnosis. Moreover, the system reliability and availability are greatly improved by following the design of a safety system.

The system complies with the IEC61131-3 standard, and has obtained various certifications such as CE, Achilles Level II, Classification Society, and G3. It can be integrated with CCS, SIS, PLC, AMS, Batch, ODS, SCADA, RMIS, MES and other systems, and provide the drive interfaces of many well-known manufacturers' control systems, to realize the seamless data transmission between intelligent field instrumentation equipment, control systems and enterprise resource management systems.

➡ The Features of HOLLiAS MACS-K are as Follows:

High Reliability

Full Redundancy:

Redundant configuration is available in every aspect, from the system network (SNET), control network (CNET), power supply, controller to the I/O modules, protecting the system against any single-point failure.

Comprehensive Diagnostics:

Complete self-diagnostics are conducted by the controller and I/O modules all the time. All types of faults, such as communication failure, open wire, short circuit and over range, can be detected and reported to the operator in a timely manner.

Multiple Isolation:

System power and the field power are supplied separately; channel fault is isolated.

Harsh Environment Adaptability:

The system is built to perform under harsh industrial environment, with the EMC requirements compliant with IEC 61000 and the airborne contaminants level satisfying ISA S71.04 G3. System reliability meets China Classification Society certification requirements

High Safety

PowerPC-architecture industrial grade processor is adopted for the controller, which is based on real-time operating system and built-in with anti-network storm components. Multi-bit digital value and signal quality judgment are also adopted for fault-oriented safety.

Design concept of safety system is followed, such as signal quality bit judgment, fault-oriented safety, to improve the system reliability. Hot swap with anti-mixing pins is supported, and 220VAC channel protection via a reinforced base is provided.

Fail-safe technology: The whole system follows the safety design concept, and the signal quality is verified before the logic calculation. The output can be automatically

switched to the preset safe value in case of failure. ECC memory error detection is supported.

Information security: It provides controller and the configuration software with information security protection through various means such as industrial security gateway, industrial firewall, industrial intrusion detection system, industrial cybersecurity audit system, industrial log analysis system, industrial whitelist, industrial host reinforcement, industrial security management platform etc., in many aspects such as identification, access control, security audit, communication integrity, communication confidentiality, software fault tolerance, resource control etc.

Advanced

- Intelligent configuration, such as configuration wizard, automatic generation of system cross-reference information, etc.
- Advanced functions, such as various advanced control modules, dedicated control modules, system function call interfaces, etc.
- The system has reached the international level of equivalent systems.

Openness

- OPC interface and ODBC are supported, with open network structure (industrial Ethernet) and Web interface.
- The HOLLiAS MACS V6 system can be seamlessly integrated with other HollySys products, including CCS, SIS, PLC, AMS, Batch, ODS, SCADA, RMIS, MES, etc., to provide users with an comprehensive solution.
- Profibus-DP/PA, Modbus-RTU/TCP, HART and other device access are supported.
- Third-party ActiveX components are supported on the HMI for easy expansion; online operation of third-party applications is supported.
- Custom function blocks, faceplates and symbols are supported.
- The software is platform-based, and multiple industry packs and languages are supported.

System Network Architecture

HollySys process automation solutions are shown in the figure below, including HOLLiAS MACS-K DCS at Level 1/2 Process Control Level, HollySys process optimization applications at Level 3, and enterprise management applications and industrial cloud applications at Level 4.

HOLLiAS Process Automation Solutions

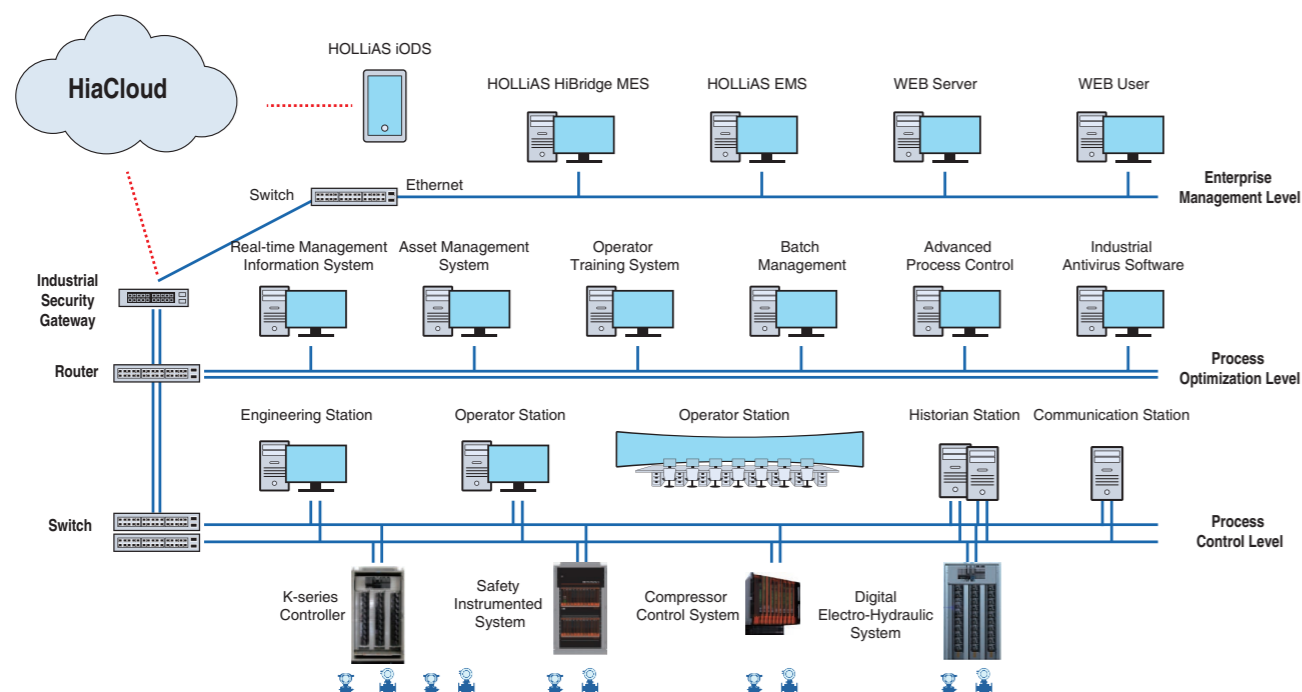

Enterprise Management Level

Enterprise Management Level includes HOLLiAS HiBridge MES (Manufacturing Execution System), HOLLiAS EMS (Energy Management System), etc.

Process Optimization Level

Process Optimization Level includes HAMS (HOLLiAS Asset Management System), SimuPlant OTS (Operation Training System), HOLLiAS BATCH, HOLLiAS APC (Advanced Process Control System) etc.

Process Control Level

The process control layer includes historian station, engineering station, operator station, communication station, control station, system network, network switch, etc. The communication is processed through redundant industrial Ethernet TCP/IP protocol.

The controller communicates with the I/O devices through the redundant IO-BUS. The I/O device transmits the collected temperature, pressure, flow, liquid level and other data to the controller. The controller processes the data according to the pre-configured control strategy and converts the results into output control signals to the actuators through I/O modules to regulate the process values and control the process variables within a certain range. At the same time, all necessary data will be transmitted to the upper level (HM) for display and storage, and the user operation instructions will be transmitted to the controllers at the lower layer.

Each device is connected to a network through two sets of network switches, and important assets (such as historical stations, switches, etc.) are redundantly configured to ensure the reliability of system communication.

Historian Station

It is used for collecting, storing and archiving the historian data of the system, and exchanging information with the factory management network. There is at most one set of redundant historian stations per domain.

The historian station mainly includes real-time services, historian services, alarm services and I/O services, through which data such as alarms, logs and trends can be collected and stored for the operator station to use.

Engineering Station

The engineer station is a platform for controller programming, graph edit and engineering maintenance. The engineering stations can be divided into master engineering station and slave stations. The project files only exist on the master engineering station. The slave engineering stations can collaboratively open the project files on the master engineering station, and update the files by modifying and saving.

The configuration software to be installed on the engineering station is as follows:

- Controller programming software for configuration of hardware configuration, as well as control logic programming, downloading and online monitoring.
- Graph edit software for configuring process flow diagrams, operation faceplates, pop-up windows, etc.
- The historian station and operator station can also be installed on the engineering station, to realize the complete functions of engineering station, historian station and operator station.

Operator Station

The operator station is a human-machine interface for operators to monitor and control the production process, maintain equipment and deal with accidents, and conducting centralized operation and monitoring for production process. The operator station can obtain real-time data by communicating directly with the control station, and dynamically display real-time/historical data in the form of flow charts, trend charts, etc., instead of relying on the transit from historian station, thereby it greatly increases system stability and reliability.

It supports high-resolution and wide-screen display, as well as multiple screens for one station. It can provide flowchart, trend chart, alarm window, control group, system status information and other monitoring interface.

A specialized operator keyboard is optionally available at the operator station. The operator keyboard has a variety of common buttons and custom function buttons. Each operator keyboard is equipped with 48 custom buttons, which can be configured into specialized commands that invoke the corresponding flowchart.



Communication Station

The communication station is mainly used for installation and running of HOLLiAS iCOMM universal communication software. It can work as OPC Server or read and write data to third-party OPC Server as OPC Client, and realize simultaneous communication with multiple devices.

Control Station

The control station is used for field signal acquisition, logic operation and control output, meanwhile it uploads the data and diagnostic results to the historian station and the operator station through the system network.

System Network

The system network is the main network of HOLLiAS MACS-K system, that is composed of 100/1000M high-speed redundant network. It is used for the connection of system historian station, operation station, engineer station, controller, communication station, and network printer. It can quickly build up a high-speed redundant security network of star, ring or bus topology, therefore it can complete the data monitoring of the whole system, and respond to various operation requests of operators, such as graphic switching, data display, trend display 100 display, report printing, screen copy, Table log query, etc.

Star topology

The IO-BUS module K-BUS02 has a total of 8 branches, which are completely logically isolated from each other and are mutually independent bus segments. Taking the A network as an example, the A1~A6 is connected to the I/O module in the local cabinet, the A7 is connected to the controller (internal port), and the A8 is connected to the remote I/O module of the expansion cabinet. When the number of I/O modules in the control station > 30, it is recommended to use a star topology, as shown in Figure 2.

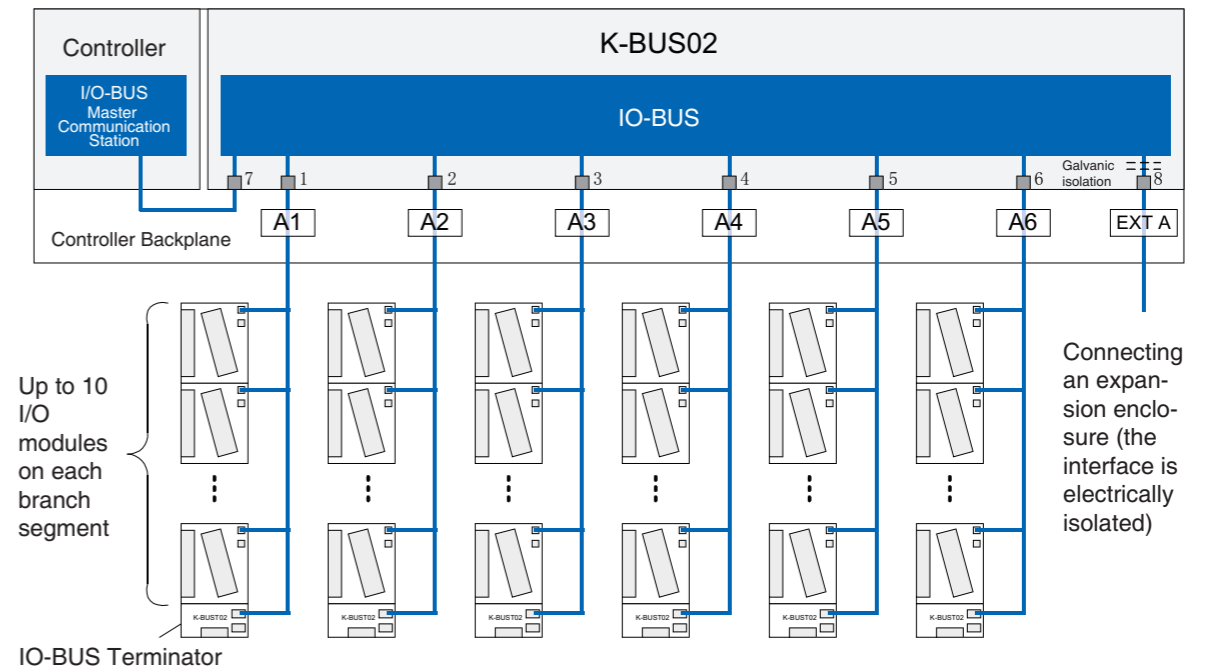

Schematic diagram of I/O-BUS bus Architecture (taking A network as an example)

Bus topology

The IO-BUS module K-BUS03 has a total of 8 branches. Take A network as an example: “S” type serial connection in the order of A1A2...A6EXT A. A1~A6 is connected to the I/O module in the local cabinet, the A7 is connected to the controller (internal port), and the A8 is connected to the remote I/O module of the expansion cabinet. When the number of I/O modules in the control station ≤ 30, it is recommended to use a bus topology, as shown in Figure 3.

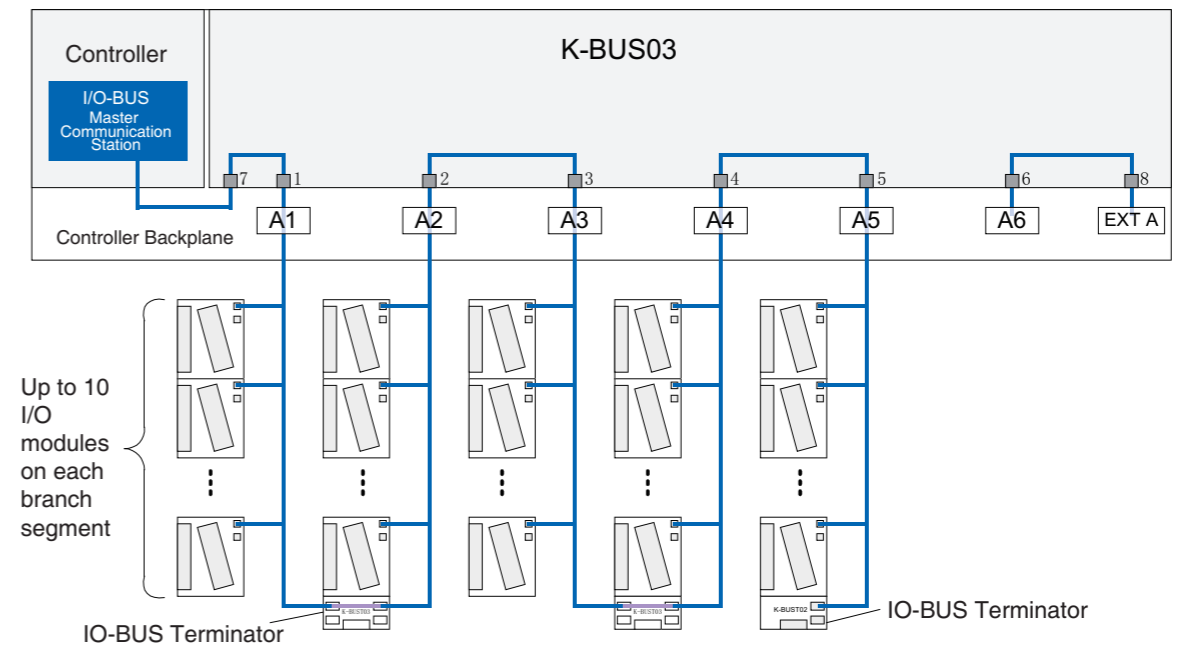

Schematic diagram of I/O-BUS bus Architecture (taking A network as an example)

System Hardware

Cabinet

The standard cabinets are of frame structure with front and rear doors, removable left and right side panels, and the side panels can be purchased separately. The front and rear doors of the cabinet are designed with ventilation holes and dust cover; the top of the cabinet is designed with an exhaust unit; the inside of the front door is designed with a document pocket, and the top of the cabinet is designed with four lifting rings. There is rubber insulation between the plinth and the cabinet body. There are two grounding bolts (M8) under the rear of the cabinet, and there are four M15 pin screw holes under the cabinet base.

There are I/O main cabinet and I/O expansion cabinet. Both cabinets are with same size of H 2200 x W800 x D600 mm, and both are equipped with protection level. The cabinet adopts DIN35 standard rail for the installation of K series modules, divided into 3 columns with front and rear installation. The cable entry from field fully follows the principle of hand from left to right.



Typical configuration list of main cabinet

S.N.	Item	Description
1	Controller unit	-
2	IO-BUS devices	-
3	Auxiliary power distribution board	K-PW21
4	MCB	2 Nos. of AC incoming power: UPS and utility
5	AC/DC power conversion module	
6	AC power distribution board	K-PW01
7	DC power distribution board	K-PW11
8	I/O and gateway devices	-
9	IO-BUS connector or terminator	-
10	Prefabricated cables	-
-	Cabinet	Including fans, lighting etc.

Power Supply

Power supply isolation between system power, field power and auxiliary power is adopted on field control station:

- System Power: Power supply to digital circuits, CPUs of I/O modules, and communication circuits.
- Field Power: Power supply to analog circuits, A/D conversion circuits, and line diagnostic circuits.
- Auxiliary Power: Power supply to DI interrogation.

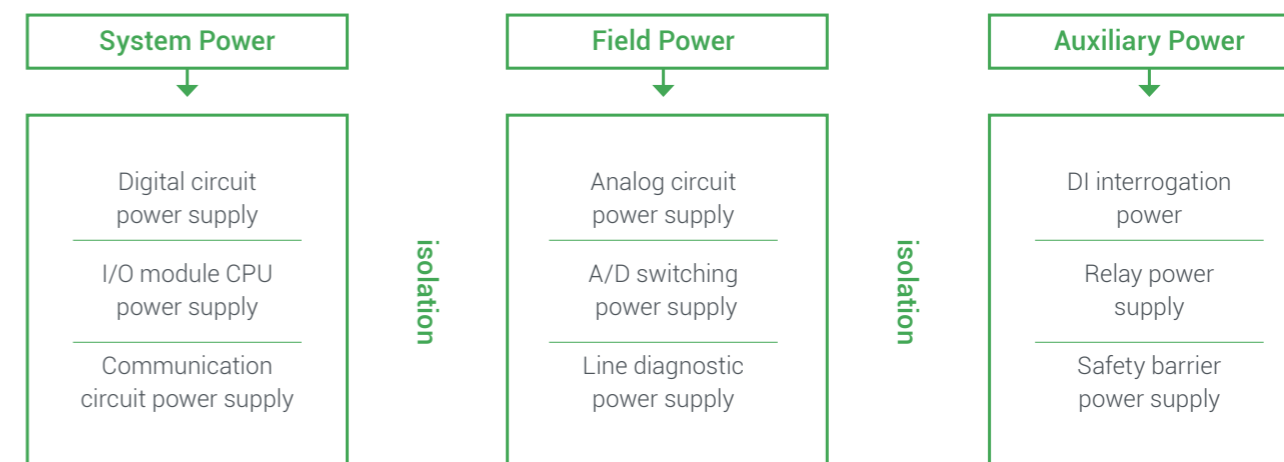

AC Power Distribution Board



Features of K-PW01:

- Supporting redundant 110/220VAC inputs.
- Supporting redundant output, each output has an independent switch and indicator.
- The design of built-in redundant high-performance EMC filter prevents grid interference and inverter interference.

Features of K-PW02

- 2 Nos. of K-PW02 are used for redundant power distribution, which meets the requirement of hot swap, and improves the maintainability of the system.
- Supporting 110/220VAC input.
- Each output has independent switch and indicator.
- Built-in high-performance EMC filter design ensures output power stability.
- Electrical gap meets the requirement of reinforced insulation with enclosure grounding design.

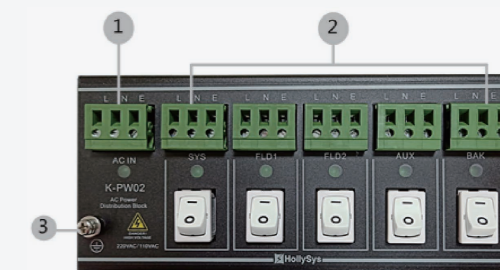

DC Power Supply

HPW2405G:

24VDC (120W) power module, AC input/24VDC output

HPW2410G:

24VDC (240W) power module, AC input/24VDC output

HPW2420G:

24VDC (480W) power module, AC input/24VDC output

HPW4803G:

48VDC (120W) power module, AC input/48VDC output

Features:

- Input voltage: 85~264VAC
- Supporting redundancy (with redundant module HPWR01G)
- Protection: short circuit / overvoltage / overcurrent / overload / over temperature / fault alarm
- Power output status indication



DC Power Distribution Board

Redundant distribution of the DC power output from the AC/DC power conversion module.

Features of K-PW11:

- 1 No. of K-PW11 ensures redundant DC power input.
- Equipped with DC power status detection interface.
- Electrical clearance meets the requirements enforced insulation with enclosure grounding design.

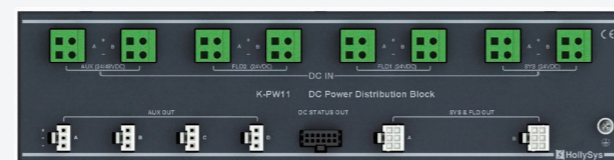

Features of K-PW12

- Used with high performance controller
- 1 No. of K-PW12 ensures redundant DC power input.
- Equipped with DC power status detection interface.
- Electrical clearance meets the requirements enforced insulation with enclosure grounding design.

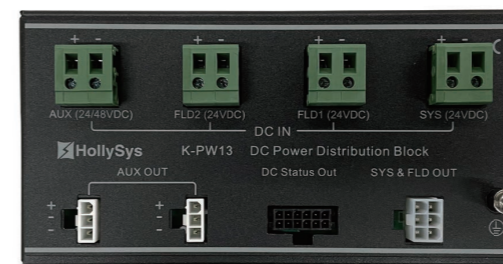
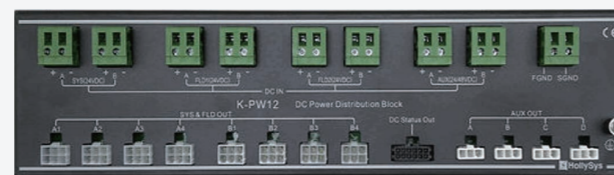

Features of K-PW13

- 2 Nos. of K-PW02 are used for redundant power distribution, which meets the requirements of host swap, and improves the maintainability of the system.
- Equipped with DC power status detection interface.
- Electrical clearance meets the requirements enforced insulation with enclosure grounding design.

Features of K-PW14

- Used with high performance controller
- 2 Nos. of K-PW14 are used for redundant power distribution, which meets the requirements of hot swap, and improves the maintainability of the system.
- Equipped with DC power status detection interface.
- Electrical clearance meets the requirements enforced insulation with enclosure grounding design.

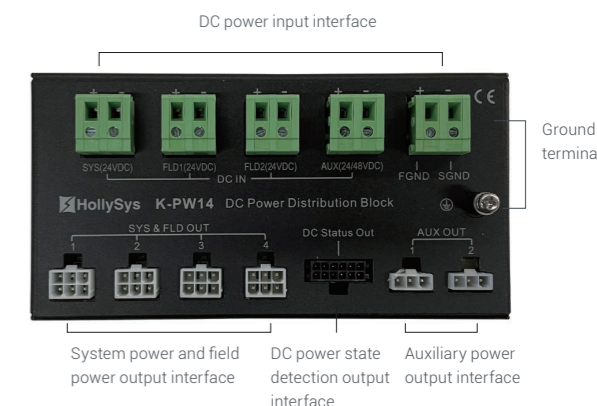

Auxiliary Power Distribution Board

Power supply to digital I/O modules, relays, and safety barriers.

Features of K-PW21:

- 16 outputs
- Supporting 24/48VDC
- Short Circuit Protection (Recovery Insurance)
- Fault indication light

Controller

The controller receives the field data and outputs the corresponding control signal according to the control logic to realize the control of field devices; meanwhile the data is provided to the upper-level machines.

Through IO-BUS, the controller communicates with the I/O device to collect field data and transmit control data.

Through Ethernet, the controller communicates with the upper-level machines to upload the process data and diagnostic data.

Through INNER-BUS, the controller works as Modbus TCP master station and supports Modbus TCP slave stations to realize data communication (only available for K-CU03).

Features of K-CU11

- Supporting redundant configuration
- Supporting System Network (SNET) redundancy
- Supporting Control Network (CNET) redundancy
- ECC verification function
- Supporting maximum 100 I/O modules

Functions:

It adopts PowerPC-architecture high-performance processor which is widely used by mainstream DCS and safety platforms. It is built in with hardware fault diagnosis, temperature status diagnosis, and can obtain data such as cabinet temperature, power supply status, etc. with IO-BUS module. It is also with power-off protection and reset functions.

The operation cycle of K-CU02 can be 50ms minimum, at which the maximum number of modules supported by the system is 65 (including K-FC01 ≤ 3, K-SV01 ≤ 24), and it is mainly used for DEH and ETS.

K-CU11 is based on K-CU01, and equipped with a SM3 encryption algorithm processor, which complies with the IEC62443-3 standard. Meanwhile the storage area has been increased to realize trusted boot and dynamic trust measurement.



Features of K-CU03

- Supporting redundant configuration
- High-speed processor
- High safety, quick redundancy speed
- Quick response on control loop
- High SOE resolution
- Supporting IRIG-B time synchronization
- Single module supports redundant INNER-BUS master station
- Single module supports redundant IO-BUS master station
- Supporting redundant system network (SNET) with DDRECC verification function
- Supporting scalable third-party gateway interface
- Supporting maximum 4,800 physical points by single control station

Functions:

Adopting 800MHz industrial-grade Power-PC processor, it can realize control loop response time within 30 milliseconds from input to output, which fully meets requirement of fast applications such as DEH and ETS. K-CU03 adopts a new design of hardware and software architecture. The hardware architecture has strong scalability, and the software architecture achieves higher information security level, faster redundancy switching performance, and can be directly connected to Modbus TCP.

It is built in with hardware fault diagnosis and temperature status diagnosis, and can obtain With the IO-BUS module, it can obtain data such as cabinet temperature, power supply status, etc. with IO-BUS module. It is also with power-off protection and reset functions.



IO-BUS Module

The IO-BUS module is the core communication device that connects the controller and the I/O card, that has the function of the IO-BUS hub to achieve data exchange. I/O module bus can be star topology, bus topology and mixed topology. Meanwhile, the controller bus, I/O module bus, and external expansion bus are electrically isolated.

K-BUS02

Feature:

- Hot swap
- IO-BUS link detection
- DC power status detection
- Cabinet temperature detection

Functions:

- Link detection function: including IO-BUS long-time logic "0" fault, and reporting fault information to the controller.
- DC power status detection: the DC power status can be detected with K-PW11
- Cabinet temperature detection: The temperature measurement range is -20°C ~60°C , and the temperature data is reported to the controller and displayed on the system status graph of the OPS.



K-BUS03

Feature:

- Hot swap
- DC power status detection
- Cabinet temperature detection

Functions:

- DC power status detection: the DC power status can be detected with K-PW11.
- Cabinet temperature detection: the temperature measurement range is -20°C ~60°C , and the temperature data is reported to the controller and displayed on the system status graph of the OPS.



K-BUS04

Feature:

- Hot swap
- IO-BUS link detection
- DC power status detection
- Cabinet temperature detection

Functions:

- Link detection function: including IO-BUS bus long-time logic "0" fault, and reporting fault information to the controller.
- DC power status detection: the DC power status can be detected with K-PW11 or K-PW12
- Cabinet temperature detection: the temperature measurement range is -20°C ~60°C , and the temperature data is reported to the controller and displayed on the system status graph of the OPS.



Topology

Star topology, Single cabinet

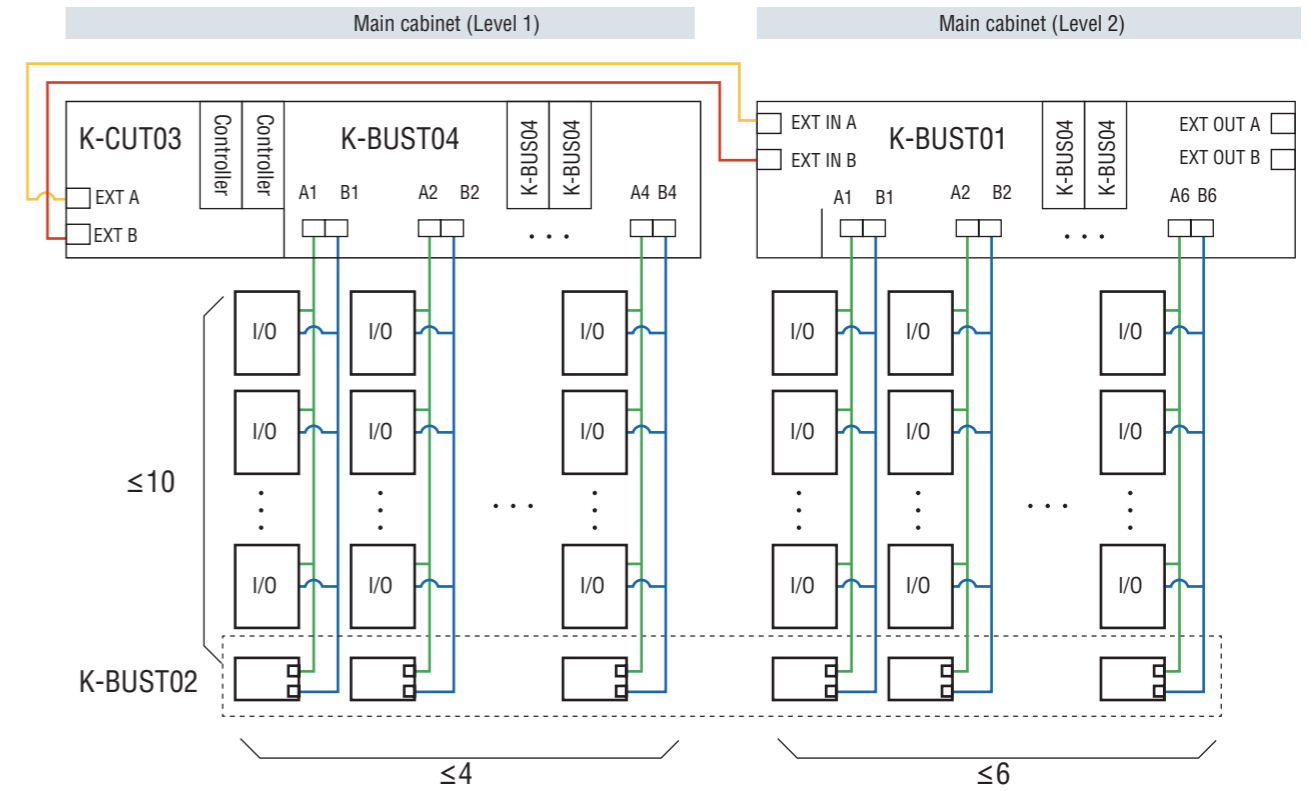
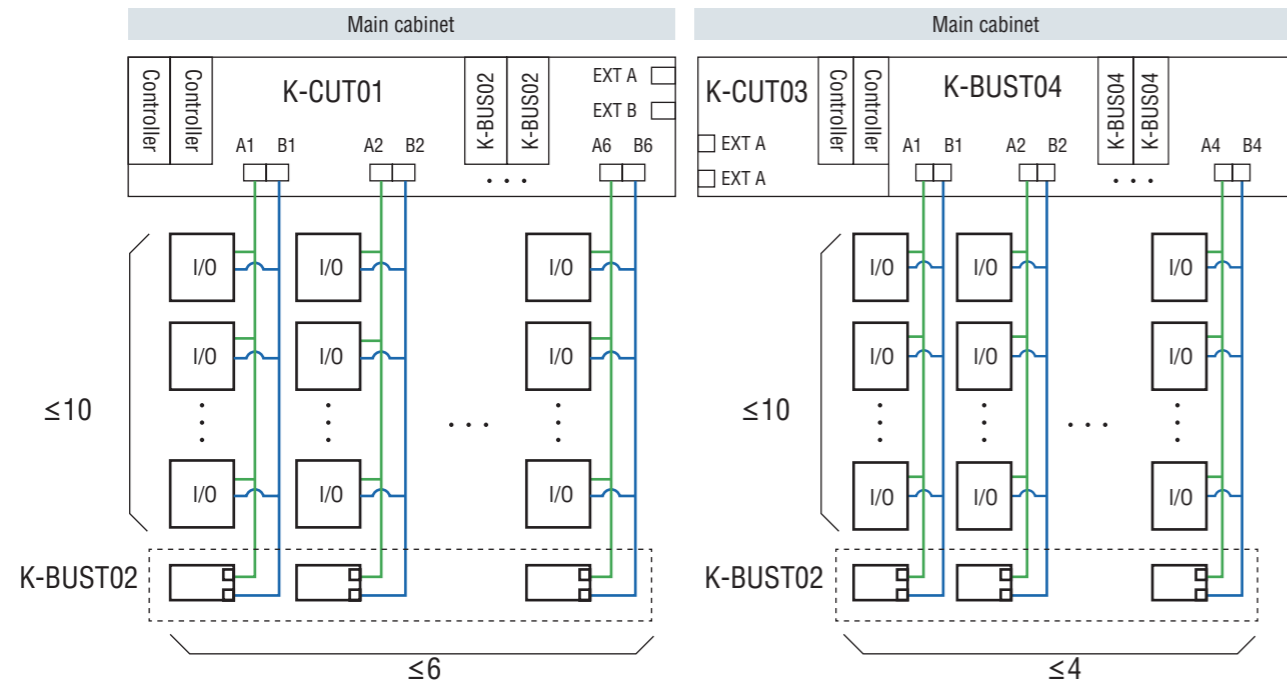

Multiple cabinet

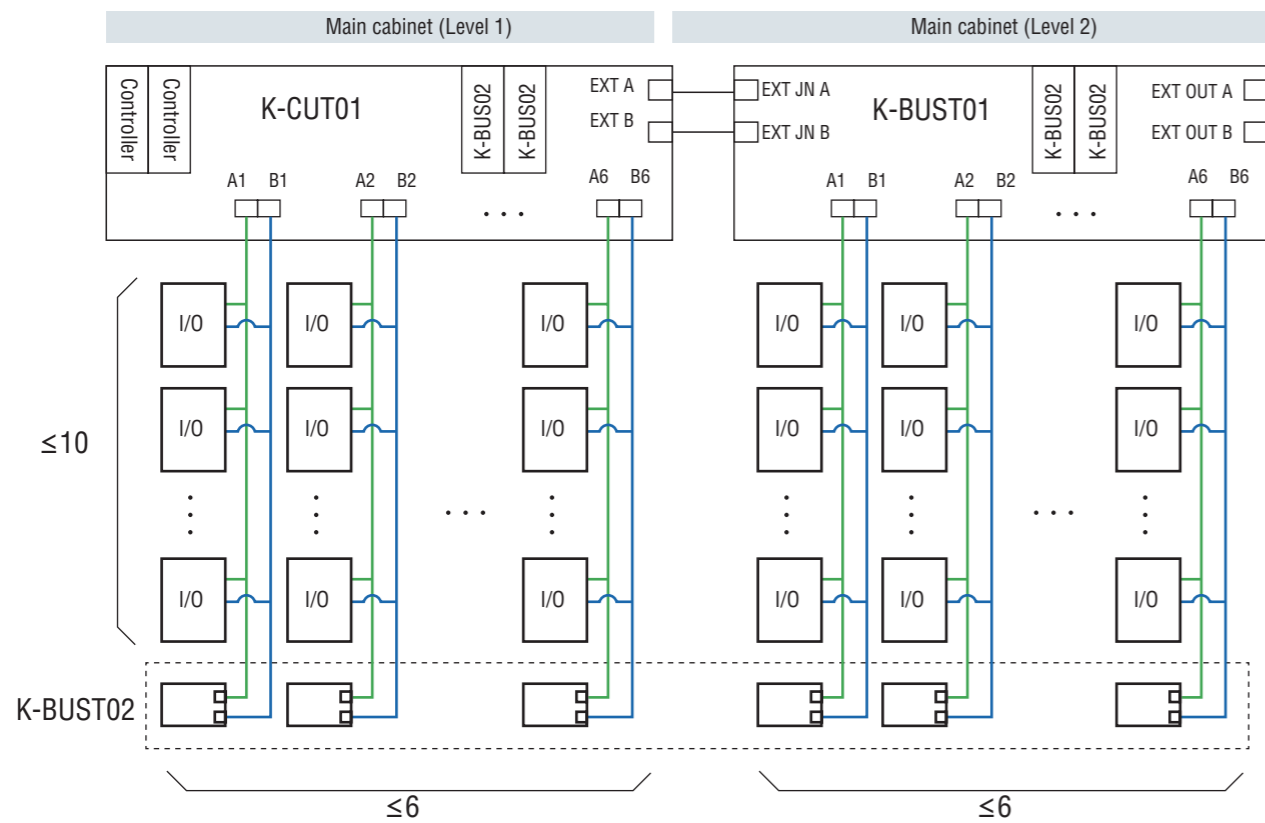

Bus topology

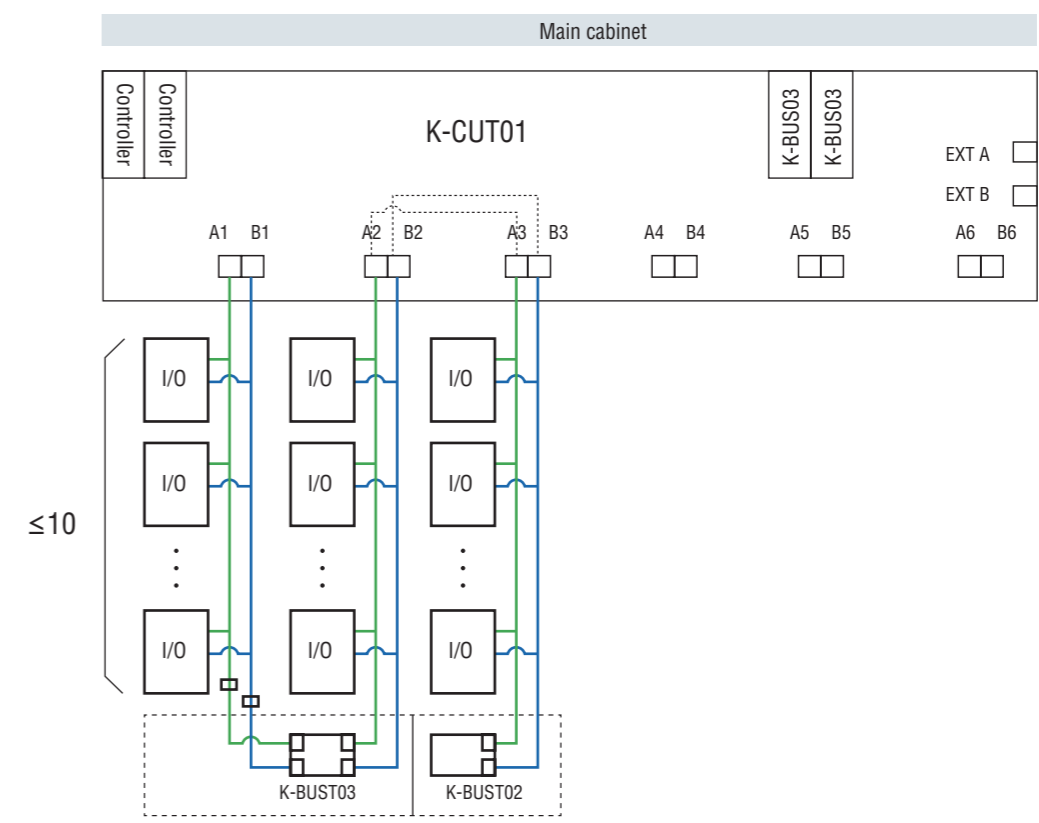

Mixed topology

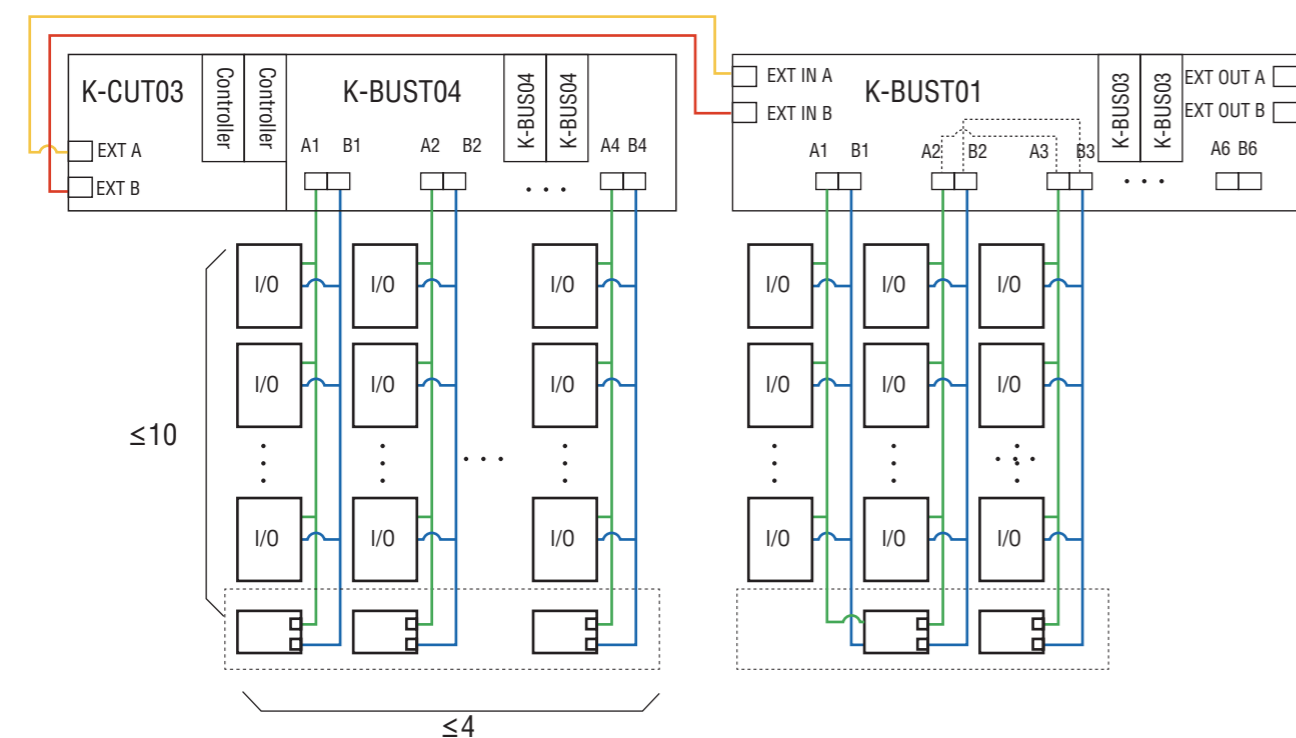
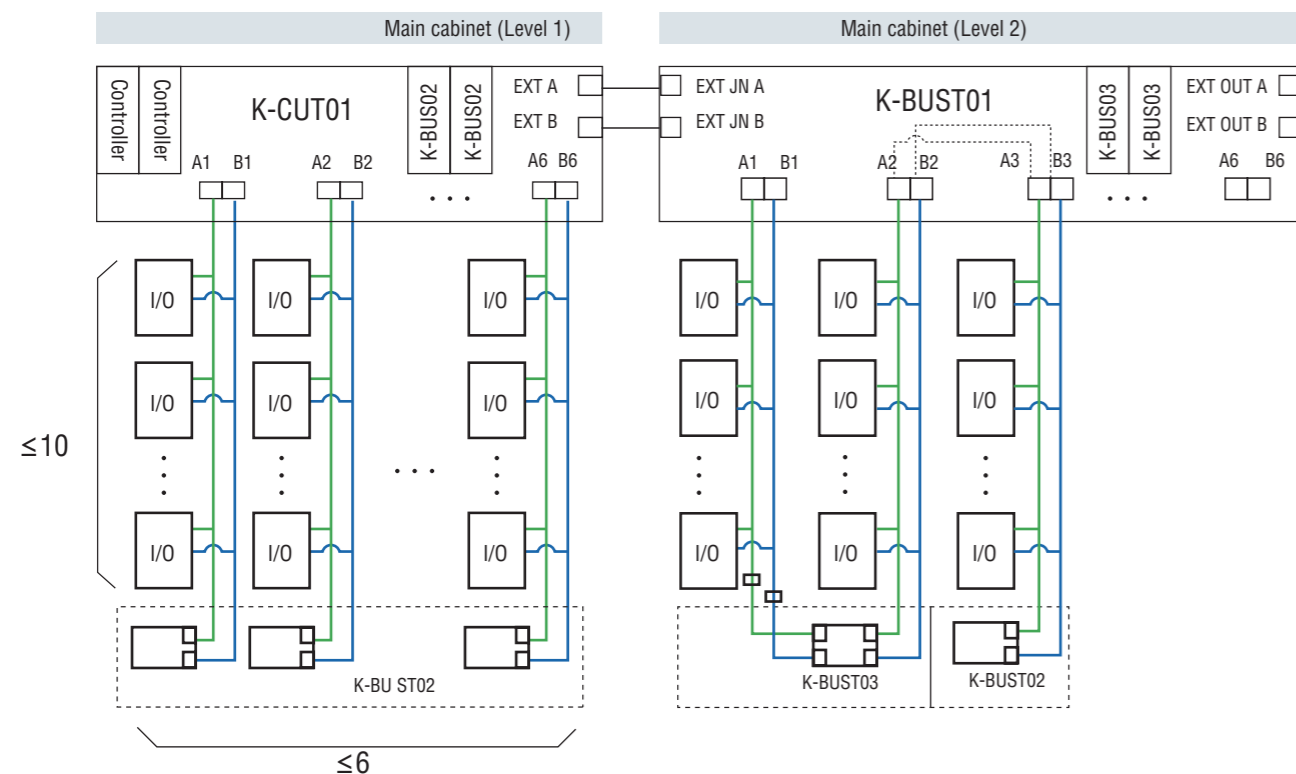

I/O Module

The I/O module is mainly used to convert and transfer data/commands between the controller and the field instrument/actuator. The I/O devices communicate with the controller through IO-BUS.

I/O devices are mainly consisting of:

- I/O module
- I/O base
- Terminal board

Feature:

- Channel isolation
- Channel transmission data verification
- Module fault diagnosis
- Abundant indication lights
- Hot swap
- Anti-mixing design



Basic Functions:

- Supporting redundancy function
- Supporting input and output of various signals
- Adopt the design concepts with safety system, such as signal quality bit judgment and fault-oriented safety, to improve system reliability.
- Power isolation technology, field power supply and system power supply are separated, and field interference will not affect the digital circuits and communications.
- Built in with module self-diagnosis, including field power supply fault, IO-BUS redundant network fault, and module board-level fatal fault.
- Built in with powerful fault diagnosis function, it can quickly diagnose various channel faults and various equipment faults such as open wire, short circuit, over-range, switch value jitter, etc., and report it in time.
- When the I/O module is configured with an enhanced base, it can resist 220VAC power. When the channel terminal is misconnected to 220VAC, it can protect the system and module from damage.

Communication Modules

MACS-K system supports PROFIBUS-DP, PROFIBUS-PA, Modbus, Modbus TCP and other protocols, and it also provides corresponding interface modules. All field signals are optically isolated from the system side to minimize the impact of faults on the system.

Profibus-DP

Features:

- Module fault diagnosis
- Abundant indication lights
- Supporting redundancy mode (base redundancy, SR redundancy)
- Supporting instrument standard diagnosis
- Electrical load capacity ≤ 31 Profibus-DP devices at field
- Hot swap
- Anti-mixing design



Functions:

DP LINK bridge communication module is used to realize the network conversion between the redundant Profibus-DP master station and the redundant or non-redundant Profibus-DP devices. It has the functions of device diagnosis and field-side communication fault diagnosis. When a fault is diagnosed, the module will report the diagnosis data to the operator station and display it on the OPS.

Profibus-PA

Features:

- Module fault diagnosis
- Abundant indication lights
- Supporting redundant mode (base redundancy)
- Supporting instrument standard diagnosis
- Electrical load capacity ≤ 20 Profibus-PA devices at field
- Hot swap
- Anti-mixing design
- Compatible with SM/FM/K series hardware



Functions:

Profibus-PA bridge communication module is used to realize the network conversion between the redundant Profibus-DP master station and the redundant or non-redundant Profibus-PA devices. It has the functions of device diagnosis and field-side communication fault diagnosis. When a fault is diagnosed, the module will report the diagnosis data to the operator station and display it on the OPS.

Modbus

Features of K-MOD01 Module

- Module fault diagnosis
- Abundant indication lights
- Supporting redundant mode
- Supporting 1 channel Modbus master/slave mode
- Up to 31 field Modbus devices can be connected
- Inter-network isolation
- Hot swap
- Anti-mixing design

Features of K-MOD03 Module

- Module fault diagnosis
- Abundant indication lights
- Supporting 4 independent Modbus links
- Electrical isolation between links, and the parameters of each link can be configured independently
- Up to 31 field Modbus devices can be connected on each link
- Supporting module active and standby redundancy
- Supporting Modbus link redundancy
- Hot swap
- Anti-mixing design

Functions:

K-MOD01 and K-MOD03 are Profibus-DP/Modbus gateway modules, and exchange data with the DCS controller through Profibus-DP, with device diagnosis and field-side communication fault diagnosis. When a fault is diagnosed, the diagnostic data will be reported to the operator station and displayed on the OPS. When both the master station and the slave station are to be supported, K-MOD01 shall be selected. When only master station is to be supported, K-MOD03 can be selected. They support two Modbus transmission modes: ASCII and RTU.



Modbus TCP

Features:

- Supporting Modbus TCP master/slave mode configuration
- Supporting 2 Modbus links to work independently
- Module fault diagnosis
- Abundant indication lights
- Hot swap
- Anti-mixing design



Functions:

K-MODP01 bridge communication module is a communication module transferred from INNER-BUS communication protocol to Modbus TCP communication protocol, which can realize the function of Modbus-side master and slave station, with system diagnosis and field-side communication diagnosis. When a fault is diagnosed, the corresponding fault alarm information can be displayed in OPS. The parameter settings of the two links are supported and are independent from each other. They can be set as master and slave respectively and can also be set as master or slave at the same time.

As a master station, up to 200 of Modbus slave stations can be added to the link, and the default polling interval is 50ms. The IP address and subnet mask of the Modbus TCP network port can be configured according to the actual situation of the user. The IP addresses of the two Modbus links cannot be in the same network segment.

As a slave station, devices can be added to this link with the address range 1-247. IP address and subnet mask of the Modbus-TCP network port is configured according to the actual situation of the user. The IP addresses of the two Modbus links cannot be in the same network segment.

Other Modules

MACS-K is designed for better application in different field scenarios, supporting connection and expansion of IO-BUS.

Repeater

K-DPR01 is Profibus-DP RS485 repeater module, to amplify the Profibus-DP data signal and connect each bus segment. When the number of hardware devices in the network (all stations on Profibus-DP, including IO modules and instruments) exceeds 32, or the network communication distance corresponding to the baud rate has exceeded the specified range, K-DPR01 can be used to for network connection expansion.

Features:

Electrical isolation between each network segment: protecting interfaces, suppressing interference, and eliminating faults.

Two working modes: isolated and non-isolated.

Compatible with SM/FM/K series hardware and third-party instruments.

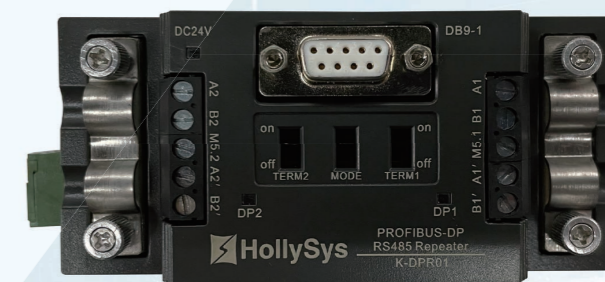

Hub

K-HUB01 is Profibus-DP hub module, to convert dual-network IO-BUS into star-type single-network IO-BUS. It supports IO-BUS interface expansion, DP interface expansion, and K-HUB01 parallel connection. Its expansion ports are equipped with fault isolation function for slave stations.

Features:

- Hot swap
- Signal relay
- Electrical isolation
- Fault isolation
- Compatible with SM/FM/K series hardware



Terminal Resistance

K-DPT01 is Profibus-DP RS485 terminal resistance module, to eliminate signal mismatch, suppress signal reflection at the end of the bus, overcome interference, and improve the communication quality of the bus. The shielding layer of the DP cable and the shielding layer of the power cable are connected to the ground through the grounding copper bar, which provides a low-impedance leakage channel for the interference signal.

Features:

Electrical isolation between each network segment: Protect interfaces, suppress interference, and eliminate faults.
Compatible with SM/FM/K series hardware and third-party instruments



System Software

Overview

The HOLLiAS MACS V6 platform is an integrated industrial automation control system developed by HollySys. With an open system software platform, and integration of HollySys' mature experience in development and use of automation systems, the system can be provided as professional solutions to meet the various requirements of different industries.

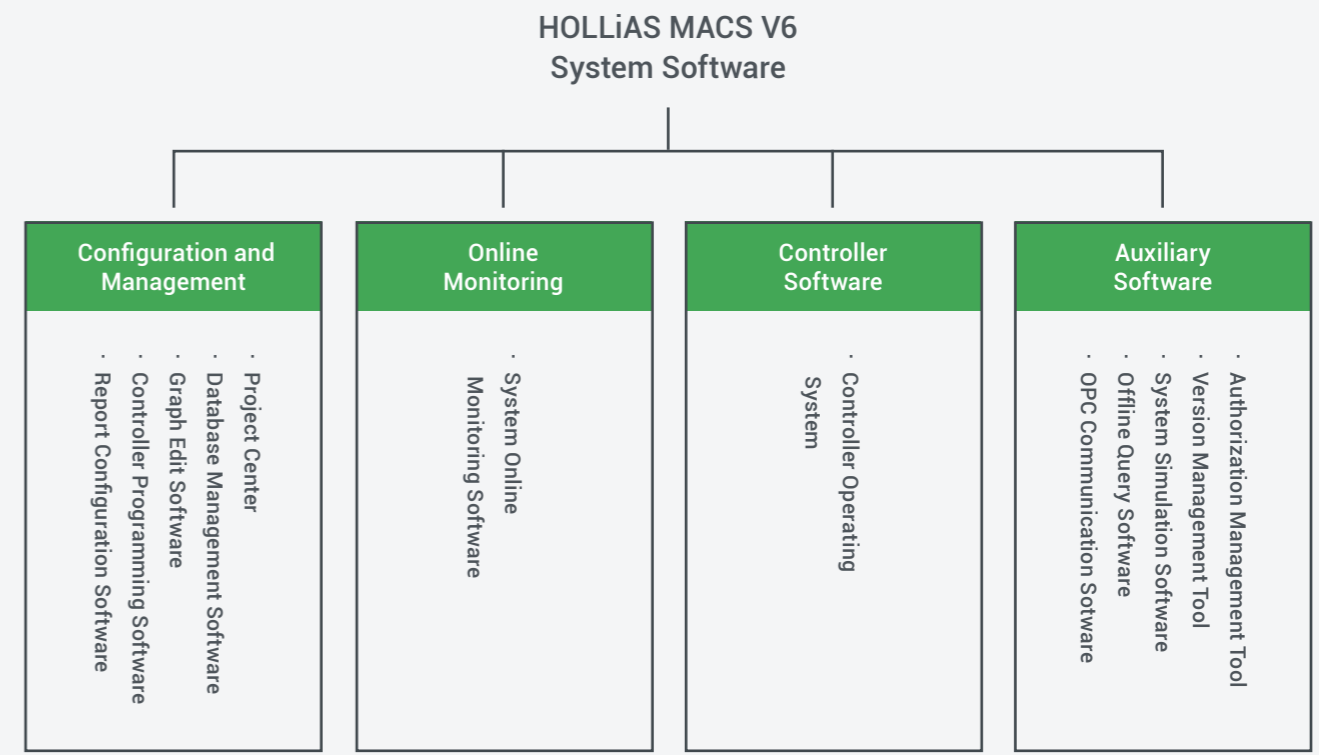

System Software Architecture

The HOLLiAS MACS V6 platform includes the following software:

System Configuration and Management Software

It is for the configuration, deployment and management of the entire DCS, including project compilation, download, project management, solution management, etc.

It is coming with integrated configuration tools and modular software; each module is integrated through COM technology; and the functions can be extended with plug-ins.

System Online Monitoring Software

It provides users with data in the form of simulated flowcharts, bar graphs, numerical tables, trend curves, reports, buttons, dialog boxes, etc., and it executes operation instructions and sends them to the field control station. It completes real-time data acquisition, dynamic data display, automatic process control, sequence control, advanced control, alarm and log detection, monitoring, and operation, it can also record, count, display, and print data.

Real-time data acquisition, dynamic data display, control operation and historical information management are finished through the cooperation of various software. Process flow charts, process parameters, data recording, alarm processing and various available data can be accessed on the system online monitoring software according to the operator's authority, and the software can also effectively adjust the output and parameter setting of the control loop.

Controller Operating System

It for field signal acquisition, engineering unit conversion, control and interlock algorithms, control output, transmission of data and diagnostic results to the operator station through the system network, etc.

Auxiliary Software

It for auxiliary configuration of DCS as well as system query and management.

The HOLLiAS MACS V6 platform has the following features:

- Clear structure of system configuration, user friendly and convenient operation interface.
- Supporting unified data management of the system, suitable for large-scale data applications.
- The operator station can control the data of multiple control domains at the same time.
- Supporting multi-engineering station collaborative configuration, the application of modification does not affect other systems in operation.
- Supporting online uninterrupted downloading and configuration simulation functions.
- Flexible operation of real-time and historical trends, support offline query of historical data.
- Supporting adaptive screen resolution, wide screen and multi-screen display.
- Supporting multi-domain architecture, multi-domain mutual access and interoperability.
- Supporting forward compatibility, software upgrade has no effect on the production process and parameters control, and will not lead to interrupt operation.
- 10. Compliant with many software standards such as OPC, COM/DCOM, ActiveX, XML, etc.

⇒ Configuration and Management Software

The main function of the system configuration management is to carry out the configuration work in engineering station, which consists of the following software:

Project Center

The Project Center software runs on the engineer station, and used to deploy and manage the entire integrated automation system.

The software integrates project creation, project management, project management, operation station user configuration, regional settings, operation station configuration, control station configuration, overview configuration, control group configuration, parameter group configuration, trend group Configuration, flow chart configuration, special keyboard configuration, database search, database import and export, report configuration, compilation, download, advanced calculation and other functions.

Please note that the project manager is domain-oriented, which means one project corresponds to one domain, and the user cannot open multiple projects at the same time to avoid confusion during configuration.

AutoThink

DCS controller program configuration software runs on the engineering station.

The software integrates the editing, management, simulation, online debugging and hardware configuration functions for controller programming, and supports IEC61131-3 compliant ST, LD, SFC languages and HollySys CFC language.

CCS-AutoThink

CCS controller programming configuration software runs on the engineering station.

The software integrates the editing, management, simulation, online debugging and hardware configuration functions for the CCS controller programming, and supports IEC61131-3 compliant LD and FBD languages.

HIC-AutoThink

ETM281 controller programming configuration software runs on the engineering station.

The software integrates the editing, management, simulation, online debugging and hardware configuration functions for the ETM281 controller programming, and supports IEC61131-3 compliant LD and ST languages and HollySys CFC language.

Safe-AutoThink

SIS (HiaGuard) controller programming configuration software runs on the engineering station. The software integrates the editing, management, simulation, online debugging and hardware configuration functions of the SIS (HiaGuard) controller programming, and supports IEC61131-3 compliant LD and FBD languages.

The above software models all use tree-like engineering organization structure to manage configuration information, with clear interface for easy use.

Graph Edit

The Graph Edit software runs on the engineering station.

Users can generate flow charts and faceplates of online operations through this software. The software provides a rich symbol library for different industries to facilitate users to draw beautiful and practical interfaces. It also supports customized symbol libraries.

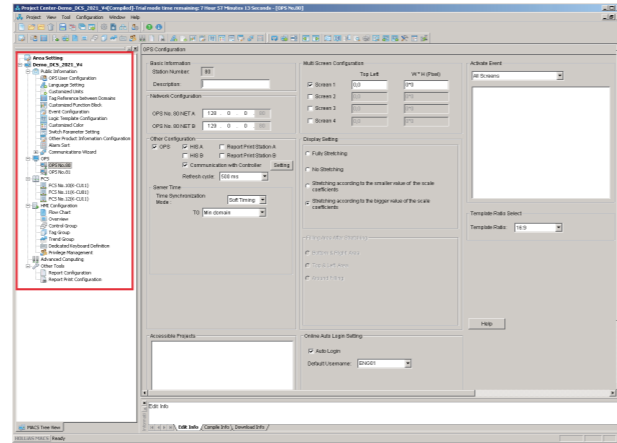

Controller Operating System Software

HOLLiAS MACS V6 controller software is independently developed by HollySys. The software has been solidified in the controller by using microchip curing technology, and is completely transparent to engineering application personnel and end users. The controller software includes the controller operating system (HEROS), industrial control application function package, communication function package, etc. to form a control engineering application platform.

Engineering application personnel use configuration software for engineering application configuration. The controller program file generated by the configuration software generates machine code program, and is downloaded to the controller user program storage area after compilation. The operating system sub-software in the controller software will automatically call the user application program in sequence, and automatically call the control function and communication function in the controller

software according to the requirements of the user application program to realize industrial automation control.

The controller programming configuration software (AutoThink) integrated in the configuration software on the HOLLiAS MACS V6 engineering station is the interface software between the engineers and the controller (software). The controller programming configuration software integrates the editing, management, simulation, online debugging and hardware configuration functions of the controller algorithm, and supports the four IEC61131-3 compliant languages – ST, LD, SFC and CFC. The controller programming configuration software adopts tree engineering organization structure to manage configuration information, and the interface is clear and easy to use. The controller programming configuration software is used after installing the HOLLiAS MACS K system engineering station software.

System Online Monitoring Software

HOLLiAS MACS V6 system online monitoring software combines the latest Windows operating system and traditional instrument operation interface, providing operators with a familiar and convenient operating environment. The software provides users with a data display human-machine interface in the form of simulation flow chart, system overview, process flow chart, control group, parameter group, alarm, trend, log, report, etc., as well as real-time data acquisition, dynamic data display, automatic process control, sequence control, advanced control, alarm and log detection, monitoring and other functions; moreover, it executes the operator's instructions and sends them to the field control station, then finishes the record, count, display, print and other data processing.

The system online monitoring software includes the functions as follow:

- System monitoring: It includes monitoring system screen, process flow chart, analog process group (overview, control group, parameter group screen), real-time alarm information, trend information, etc.
- Log record: Record all event that occurs in the system, and equipped with the functions of query and print.
- Alarm management: Realize the operator's browsing, query and confirmation of real-time and historical alarms. Main functions: alarm display, list monitoring, real-time alarm window, historical alarm window, alarm priority sorting, sound alarm, alarm acknowledgment, alarm suppression, alarm concealment, and alarm silencing.
- Trend management: Realize the query of historical data, real-time data and the display of trend curves.
- Report management: The report management software obtains data from the system historical database and real-time database; and it realizes the functions of daily report, monthly report, shift report and free time report.

Other Auxiliary Software

OPC Client

It completes the communication with third parties on OPC protocol, realizing data exchange with systems from other vendors.

Simulation Startup Management

It simulates the operation of the field control station, historical station and operator HMI.

Offline Query

It can query historical data such as system trends, alarms, and logs by conditions to help users analyze system operation or the cause of events.

Operator Online Configuration Tool

It can configure the default information of the operator HMI, including domain number, initial page routing information, etc.

Version Query Tool

It can query the version information of all files of the current system software.

View Authorization Information

It is for viewing authorization information by category and completing software license.

HSRTS Tool

This tool for upgrading the HOLLiAS MACS V6.5 system controller RTS program.

HSRTS Tool (CCS)

This tool for upgrading CCS system controller and communication unit RTS program.

HSRTS Tool (HiaGuard)

This tool for upgrading SIS (HiaGuard) system controller and communication unit RTS program.

Advanced Application Software

HOLLiAS AMS

HOLLiAS Asset Management System (HAMS) is a unified management platform of HollySys, for maintenance, verification and fault diagnosis of intelligent devices such as field instruments and regulating valves. It is an important part of the plant-wide intelligent instrument maintenance and fault diagnosis system. It is used to realize remote acquisition and configuration, status diagnosis and monitoring, maintenance analysis management and automatic log recording of various types of smart instruments, as well as conduct statistical

analysis and evaluation of device failures and provide maintenance strategy basis. So that maximum benefit can be realized, instrument wear and tear can be reduced, and maintenance cost can be decreased.

Open device integration technology and specifications are adopted to the system, and it is compatible with various types of smart meters from different manufacturers, and can avoid the use of multiple configuration tools and software.

HHBatch

Batch control software is suitable for the industrial fields with obvious intermittent and batch characteristics such as chemical, food, cosmetic, pharmaceutical. It can be used in conjunction with the HOLLiAS® MACS system to realize the management, monitoring and traceability of recipes and batch production.

This product is based on the IEC61512 standard (S88), and supports functions such as recipe management, version control, production scheduling, order modification and step skipping. From recipe ratio tables to recipe groups, and simple sequential processes to complex processes involving parallel and selection, HHBatch makes batch control operation easier and more flexible.

HOLLiAS iComm

HOLLiAS iComm is a highly reliable and general-purpose industrial real-time communication software developed by HollySys, to solve the problems of various device types, different communication protocols and different interfaces between devices in industrial automation communication. HOLLiAS iComm makes the communication easier for DCS to DCS, device to device, and device to DCS, and shares real-time data of industrial fields easily with management systems such as ERP and MES.

Appendix1 System Parameters

Item	Parameter
Electrical Parameters	
Voltage	Single phase 220VAC (-15%~+10%)
Frequency	50±2Hz
Waveform deviation factor	<3%
Isolation tolerance between field and system	≥ 1500VAC@1min leakage current<5mA
Insulation resistance between field and system	Above 100MΩ under normal conditions (temperature +25°C ±2°C , relative humidity 30%±5%, no condensation) Above 10MΩ in hot and humid environment (temperature +45°C ±2°C , relative humidity 95%±3%, no condensation)
Protection grade	IP20
Earthing resistance	≤ 4Ω
Environment Parameters	
Operating temperature	-20°C~ 60°C
Operating relative humidity	5% ~ 95%, no condensation
Storage temperature	-40°C~ 70°C
Storage relative humidity	5% ~ 95%, no condensation
Operating altitude range	-300 ~ 3000m
Operating pressure range	86kPa ~ 106kPa
Environment pollution level	Compliant with G3 ISA S71.04

Appendix2 System Capability

Item	Parameter
System Overall Performance	
Maximum domain number	15
Maximum area levels	10
Maximum area number	255
Single Domain Performance	
Maximum Operator Stations	64
Maximum Field Control Stations	64
Maximum users for collaborative engineering	64

Appendix 3 Module List

Module Type	Model	Description
Controller	K-CU01	Redundancy supported, star/bus topology, max. 2200 physical I/O's
	K-CU11	Redundancy supported, star/bus topology, max. 3200 physical I/O's
	K-CU02	Redundancy supported, star/bus topology, max. 2200 physical I/O's, for DEH
	K-CU03	High performance, redundancy supported, INNER-BUS/IO-BUS master station, max. 4800 physical I/Os
IO-BUS Module	K-BUS02	8-channel, star topology
	K-BUS03	Bus topology
	K-BUS04	4-channel, high speed, star topology
	K-BUST02	I/O BUS terminator
	K-BUST03	Bus topology terminator
Analog Input	K-AI01	8-channel, current input, redundancy (optional)
	K-AIH01	8-channel, current input, HART, redundancy (optional)
	K-AI02	8-channel, current/voltage input, redundancy (optional)
	K-AIH02	8-channel, current/voltage input, HART, redundancy (optional)
	K-AI03	16-channel, current input, redundancy (optional)
	K-AIH03	16-channel, current input, HART, redundancy (optional)
	K-AI04	8-channel, high speed, current input
Analog Output	K-AO01	8-channel, current output, redundancy (optional)
	K-AOH01	8-channel, current output, HART, redundancy (optional)
	K-AO02	8-channel, high accuracy, current output, redundancy (optional)
	K-AO03	16-channel, current output, redundancy (optional)
	K-AOH03	16-channel, current output, HART, redundancy (optional)
Temperature Acquisition	K-RTD01	8-channel, RTD input, redundancy (optional)
	K-TC01	8-channel, TC/mV input, redundancy (optional)
	K-SRT01	24-channel, RTD/TC/mV input, full metal enclosure, IP55
Digital Input	K-DI01	16-channel, 24VDC input (220VAC/relay input with terminal board), redundancy (optional)
	K-DI11	16-channel, 48VDC input (220VAC/relay input with terminal board), redundancy (optional)
	K-DI03	32-channel, 24VDC input, redundancy (optional)
	K-DI13	32-channel, 48VDC input, redundancy (optional)
	K-DI04	16-channel, high speed, 24VDC, dry/wet contact input, SOE supported, redundancy (optional)
	K-DI12	16-channel, high speed, 48VDC, dry/wet contact input, SOE supported, redundancy (optional)
	K-DI04	16-channel, high speed, 24VDC, dry/wet contact input, SOE supported, redundancy (optional)
Sequence of Event	K-SOE01	16-channel, 24VDC input (220VAC/relay input with terminal board)
	K-SOE11	16-channel, 48VDC input (220VAC/relay input with terminal board)
Digital Output	K-DO01	16-channel, transistor output (relay output with relay board), redundancy (optional)
	K-DO02	8-channel, high speed, MOSFET output
	K-DO04	32-channel, transistor output (relay output with relay board), redundancy (optional)

Module Type	Model	Description
Pulse Input	K-PI01	6-channel, dry contact, 2-wire/PNP/NPN proximity switch, 3-wire current pulse, 3/4-wire voltage pulse
Profibus-DP Communication	K-DP02	Network conversion between redundant Profibus-DP master station and non-redundant Profibus-DP devices, base redundancy (optional)
	K-DP03	Network conversion between redundant Profibus-DP master station and non-redundant Profibus-DP devices, base/SR redundancy (optional)
Profibus-PA Communication	K-PA01	Network conversion between redundant Profibus-DP master station and non-redundant Profibus-PA devices, base redundancy (optional)
	K-PA02	Network conversion between redundant Profibus-DP master station and non-redundant Profibus-PA devices, device diagnosis, base redundancy (optional)
Modbus Communication	K-MOD01	1 link, master/slave station, network conversion between Profibus-DP and Modbus devices
	K-MOD03	4 links, maser station, network conversion between Profibus-DP and Modbus devices
	K-MODP01	2 links, master/stave station, network conversion between INNER-BUS and Modbus-TCP, redundancy (optional)
Fiber Optic Converter	K-EP02	Multi-mode FO media converter
	K-EPF01	Single-mode FO media converter, system side
	K-EPS01	Single-mode FO media converter, field side
Repeater	K-DPR01	2-channel, Profibus-DP network extension
Hub	K-HUB01	6 IO-BUS extensions, conversion from dual IO-BUS to single star IO-BUS
Terminal Resistance	K-DPT01	2-channel Profibus-DP communication port, for suppressing signal reflections at the end
Terminal Conversion	K-JNCT01	Cable conversion terminal board for IO-BUS, time synchronization bus and extension bus
Power Supply	HPW2405G	24VDC, 120W, 220VAC input/24VDC output
	HPW2410G	24VDC, 240W, 220VAC input/24VDC output
	HPW2420G	24VDC, 480W, 220VAC input/24VDC output
	HPW4803G	48VDC, 120W, 220VAC input/48VDC output
	HPWR01G	for redundant distribution of 24/48VDC power
Power Distribution	K-PW01	220VAC power distribution board, redundant circuit, built-in power filter
	K-PW02	220VAC power distribution board, single circuit, built-in power filter
	K-PW11	24VDC power distribution board, redundant circuit, power monitoring supported with IO-BUS devices
	K-PW12	High performance, 24VDC power distribution board, redundant circuit, power monitoring supported with IO-BUS devices
	K-PW13	24VDC power distribution board, single circuit, power monitoring supported with IO-BUS devices
	K-PW14	High performance, 24VDC power distribution board, single circuit, power monitoring supported with IO-BUS devices
K-PW21	16-output, 24/48VDC power distribution for digital I/O module and relay	